

Front view (1 : 2)

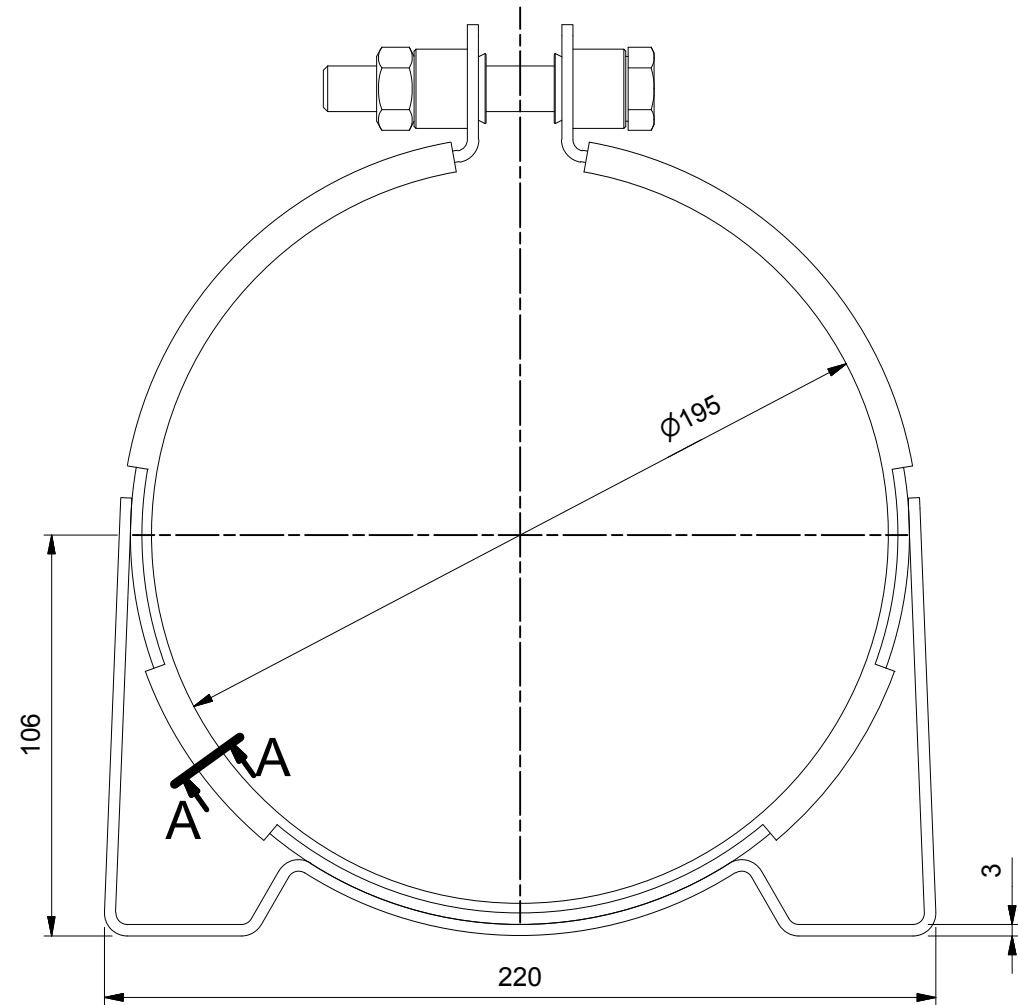

Side view (1 : 2)

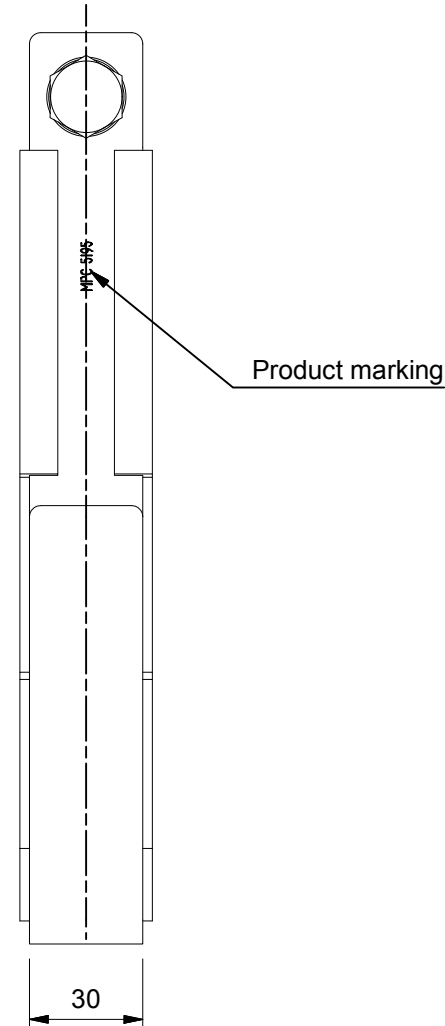

Parts identification (1 : 3)

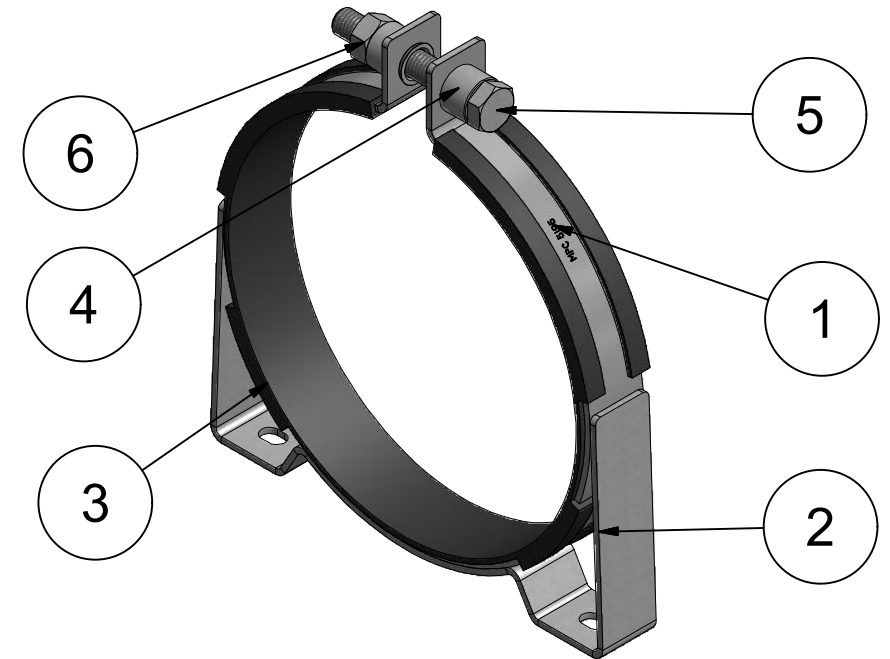

Item	Qty	Description	Material
1	1	Clamp part	Stainless Steel AISI 316
2	1	Console part	Stainless Steel AISI 316
3	1	Rubber part	EPDM Rubber Shore hardness 65°±5°
4	2	Rivet Ø21	AISI316
5	1	Srew M12x80	RVS A4-80
6	1	Hex Nut M12	RVS A4-80

Bottom view (1 : 2)

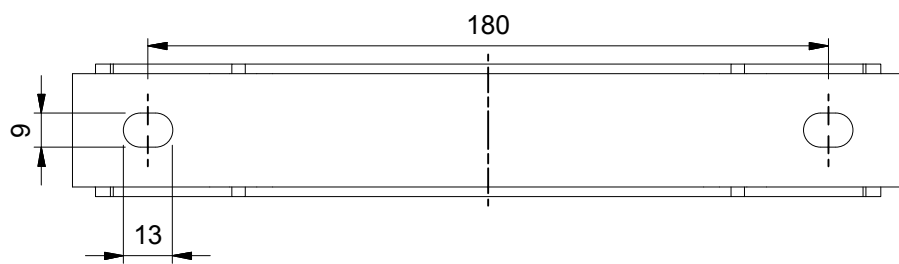

A-A (1 : 2)

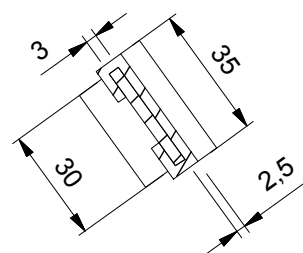

Product mark:
MPC 5195

		© 2013 MPC INDUSTRIES BV, developed and designed by MPC INDUSTRIES BV	
		General Tolerances: according to: DIN 2768-vL	
NOTICE TO PERSONS RECEIVING THIS DRAWING AND/OR TECHNICAL INFORMATION: MPC Industries BV claims proprietary rights to the material disclosed hereon. This drawing and/or technical information is issued in confidence for engineering information only and may not be reproduced or used to manufacture anything shown or referred to hereon without direct written permission from MPC Industries BV to the user. This drawing and/or technical information is the property of MPC Industries BV and is loaned for mutual assistance to be returned when its purpose has been served. THIS DRAWING AND/OR TECHNICAL INFORMATION IS THE PROPERTY OF MPC INDUSTRIES BV. DO NOT SCALE FROM DRAWING.		Material:	Dimensions:
Drawn by: Gy.Kardos Checked by: Scale 1:2 Status: Released		Doc no.: ACCU5195.dwg Third angle projection:	
Creation date: 06/01/2014 Checked date: Units: mm		Part number: ACCU5195 Description: MPC Industries Accumulator clamp, 190-195mm, W5	
Revision:		Format: A3	
MPC Industries B. V. Badweg 38 8401 BL Gorredijk Postbus 225 8400 AE Gorredijk. Tel.: . 0513 465477 Fax.: 0513 465736			