

Front view (1 : 2)

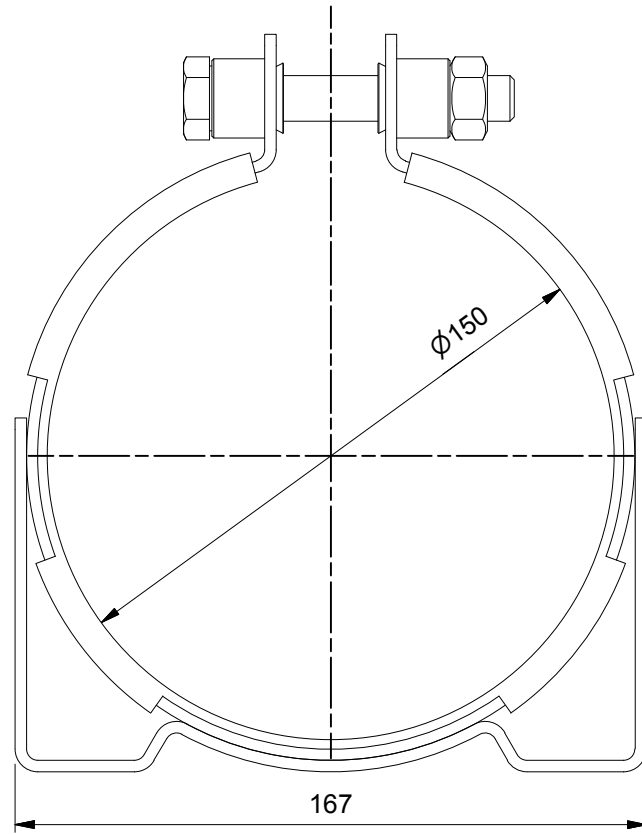

Side view (1 : 2)

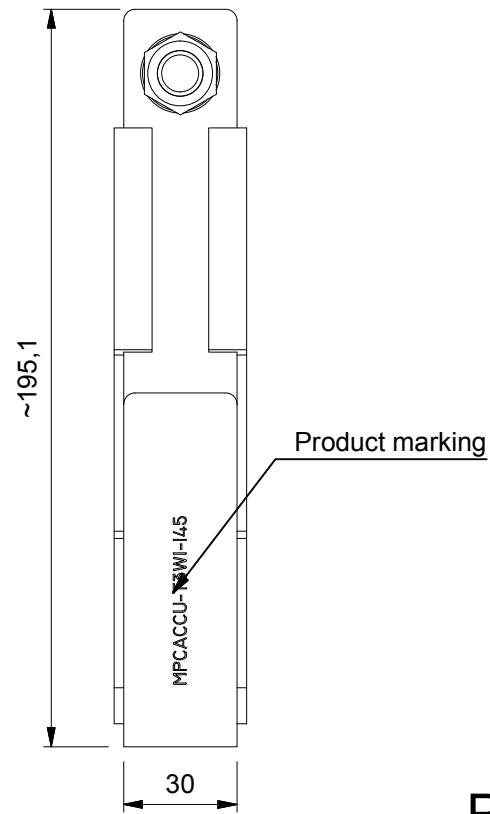

Iso view (1 : 2)



Bottom view (1 : 2)

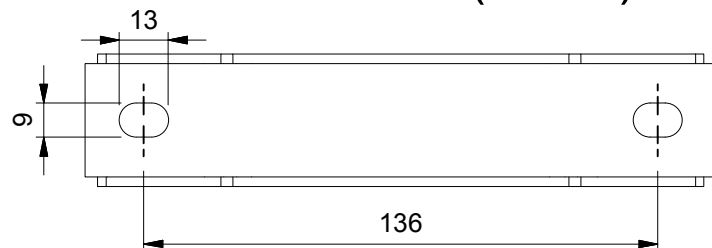

Product mark:
MPCA-T3WI-145

Item	Qty	Description	Material
1	1	Clamp part	Zinc plated Steel, Mild
2	1	Console part	Zinc plated Steel, Mild
3	1	Rubber part	EPDM Rubber Shore hardness 65°±5°
4	1	NUT M12, DIN 934	Zinc plated, ST 8.8
5	2	Rivet Ø21	Zinc plated, Steel, Mild
6	1	Screw DIN 933 M12*80 full threaded	Zinc plated, ST 8.8



© 2017 MPC INDUSTRIES BV, developed and designed by MPC INDUSTRIES BV

General Tolerances: according to: DIN 2768-vL

SURFACE TREATMENT AND OR PROTECTION:

NOTICE TO PERSONS RECEIVING THIS DRAWING AND/OR TECHNICAL INFORMATION:
MPC Industries BV claims proprietary rights to the material disclosed hereon. This drawing and/or technical information is issued in confidence for engineering information only and may not be reproduced or used to manufacture anything shown or referred to hereon without direct written permission from MPC Industries BV to the user. This drawing and/or technical information is the property of MPC Industries BV and is loaned for mutual assistance to be returned when its purpose has been served.
THIS DRAWING AND/OR TECHNICAL INFORMATION IS THE PROPERTY OF MPC INDUSTRIES BV
DO NOT SCALE FROM DRAWING.

Material:

Mass: 0.828 kg

Doc no.: ACCUT3W1145150.dwg

Third angle projection:

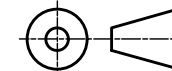

Part number:

ACCUT3W1145150

Drawn by: Gy.Kardos

Creation date: 05/01/2017

Checked by:

Checked date:

Scale 1:2

Units: mm

Status: Released

Description:
MPC Industries Accumulator
clamp, Ø 145-150 mm, W1

Revision:

Format:

A3