

Side view (1 : 1)

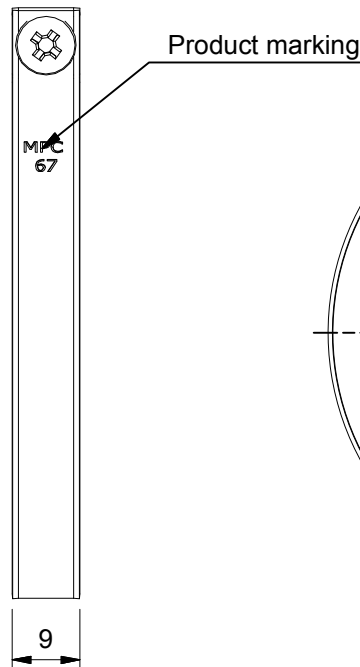

Front view (1 : 1)

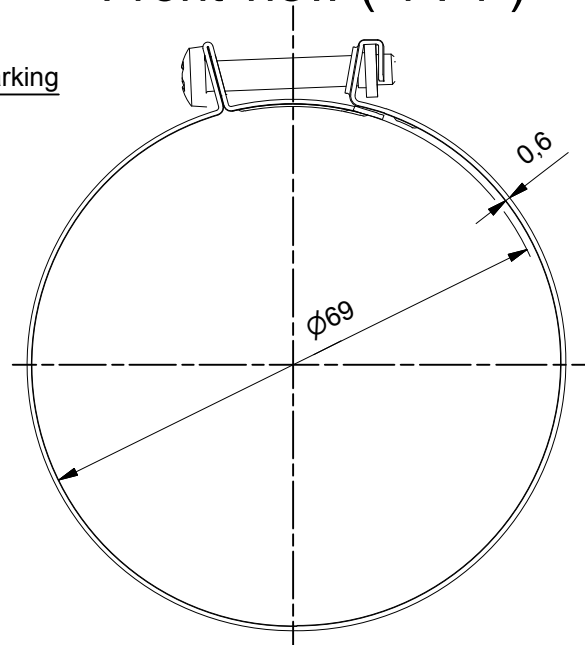

Parts identification (1 : 2)



Item	Qty	Description	Material
1	1	Band	Zinc plated, Steel, Mild
2	1	Screw M4x25	Zinc plated, St 8.8
3	1	Square nut M4	Zinc plated, Steel, Mild

Product mark:
MPC 67

Iso view (1 : 2)

Profile pressed in the band to conduct the bridge between screw and nut. It will provide smooth sliding of the bridge during tightening.



NOTICE TO PERSONS RECEIVING THIS DRAWING AND/OR TECHNICAL INFORMATION:
MPC Industries BV claims proprietary rights to the material disclosed herein. This drawing and/or technical information is issued in confidence for engineering information only and may not be reproduced or used to manufacture anything shown or referred to herein without direct written permission from MPC Industries BV to the user. This drawing and/or technical information is the property of MPC Industries BV and is loaned for mutual assistance to be returned when its purpose has been served.
THIS DRAWING AND/OR TECHNICAL INFORMATION IS THE PROPERTY OF MPC INDUSTRIES BV

Revision history			
Rev.	Date	Description	AUTHOR
-	21-11-2002	Drawing created	Martin
1	2-8-2013	Inventor drawing created	gyula
2	26-2-2014	Drawing renewed	gyula

Material:		Dimensions: mm	
Doc no.: MG067.dwg			
Third angle projection:		Part number:	
		MG067	
Drawn by: gyula	Creation date: 2-8-2013	Description: MPC Industries, Mini Giant 67mm, Range: Ø65-69mm, W1	Revision: 2
Checked by:	Checked date:		Format: A4
Scale 1:1	Units: mm		
Status: Released			
MPC Industries B. V. Badweg 38 8401 BL Gorredijk Postbus 225 8400 AE Gorredijk. Tel.: . 0513 465477 Fax.: 0513 465736			