

VIEW2 (1 : 2)

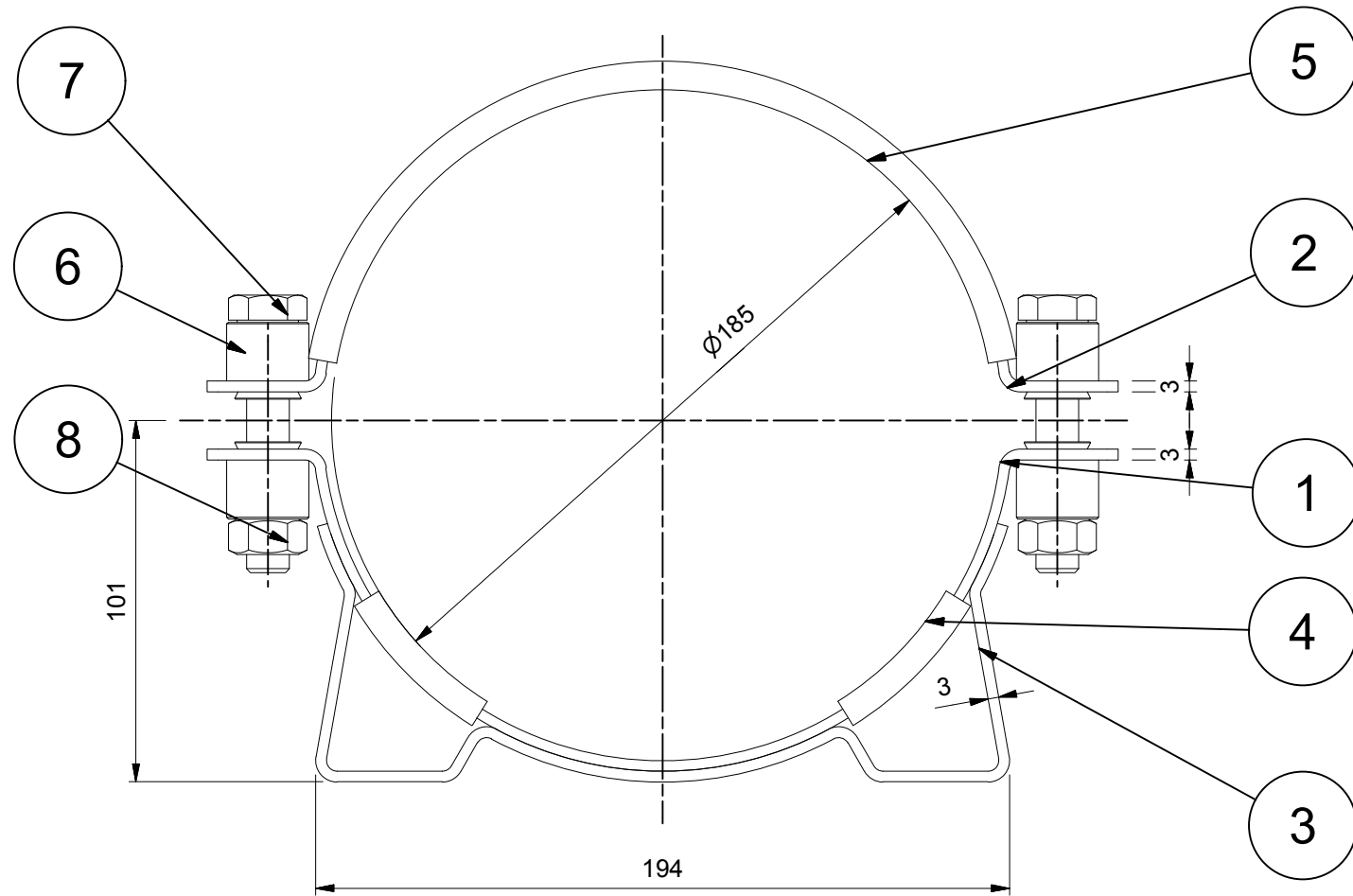

VIEW3 (1 : 2)

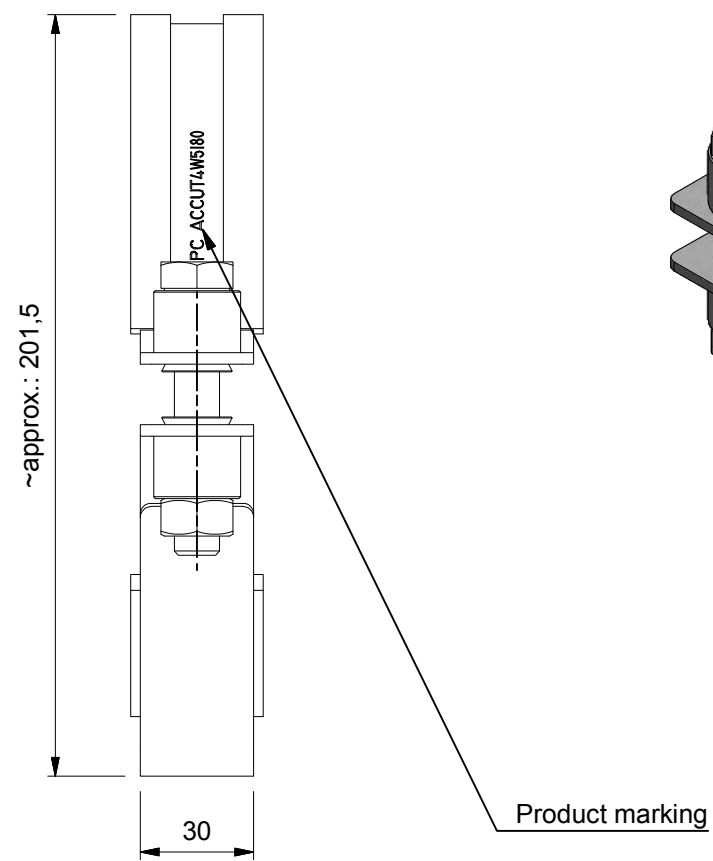

VIEW1 (1 : 2)



VIEW4 (1 : 2)

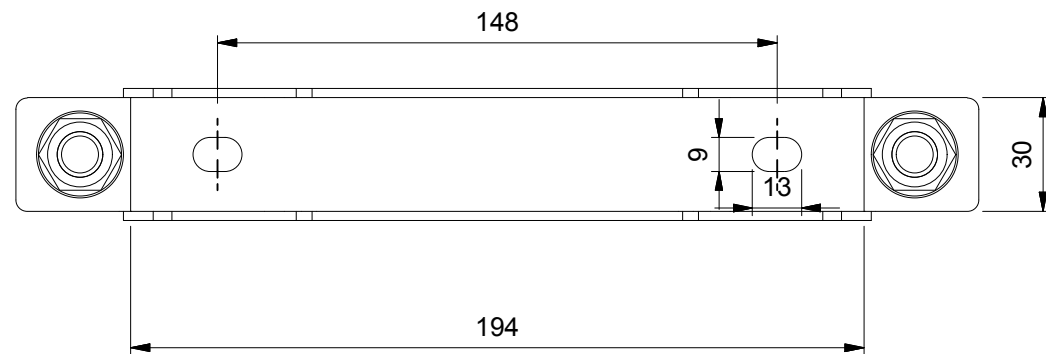

Product mark:
MPC ACCUT2W5180

Item	Qty	Description	Material
1	1	Clamp bottom part	AISI316
2	1	Clamp top part	AISI316
3	1	Console part	AISI316
4	2	Rubber bottom part	EPDM Rubber Shore hardness 65°±5°
5	1	Rubber top part	EPDM Rubber Shore hardness 65°±5°
6	4	Rivet Ø24*25	AISI316
7	2	Srew M12x70	RVS A4-80
8	2	Hex Nut M12	RVS A4-80

NOTICE TO PERSONS RECEIVING THIS DRAWING AND/OR TECHNICAL INFORMATION:
MPC Industries BV claims proprietary rights to the material disclosed hereon. This drawing and/or technical information is issued in confidence for engineering information only and may not be reproduced or used to manufacture anything shown or referred to hereon without direct written permission from MPC Industries BV to the user. This drawing and/or technical information is the property of MPC Industries BV and is loaned for mutual assistance to be returned when its purpose has been served.
THIS DRAWING AND/OR TECHNICAL INFORMATION IS THE PROPERTY OF MPC INDUSTRIES BV

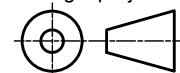
		Material:	Dimensions: -
		Doc no.: MPC-ACCUT4W5180.dwg	
Third angle projection:		Part number:	
		ACCUT4W5180	
Drawn by: gyula	Creation date: 02-Mar-12	Description: MPC Accumulator clamp type4, 175-185mm, W5	
Checked by:	Checked date:		
Scale: 1:1	Units: mm	Revision:	
Status: Released			
MPC Industries B. V. Badweg 38 8401 BL Gorredijk Postbus 225 8400 AE Gorredijk. Tel.: . 0513 465477 Fax.: 0513 465736			
			Format: A3