

# MPC TYPE "S"

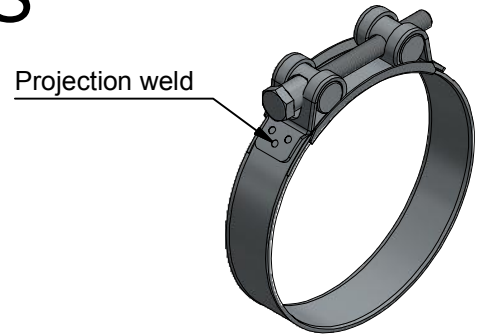
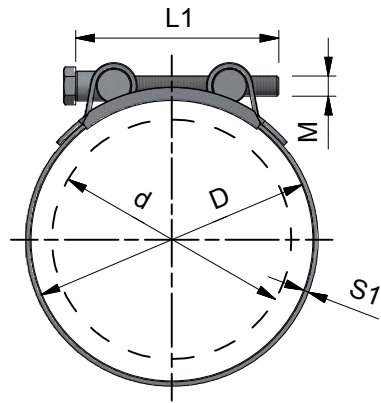

## SIZES

clamp size minimum:	clamp size maximum:	Band width:	Band W1	Thickness W2; W4; W5	Hexagon	head	screw	Tightening Torque:
d	D	B1	S1	S1	L1	L2	M	AD* in Nm
17	19	18	0,6	0,6	40	8	5	4,5 Nm
20	22	18	0,6	0,6	40	8	5	4,5 Nm
23	25	18	0,6	0,6	40	8	5	4,5 Nm
26	28	18	0,6	0,6	40	8	5	4,5 Nm
29	31	20	0,8	0,6	50	10	6	8 Nm
32	35	20	0,8	0,6	50	10	6	8 Nm
36	39	20	0,8	0,6	50	10	6	8 Nm
40	43	20	0,8	0,6	50	10	6	8 Nm
44	47	22	1,2	0,8	60	10	6	8 Nm
48	51	22	1,2	0,8	60	10	6	8 Nm
52	55	22	1,2	0,8	60	10	6	8 Nm
56	59	22	1,2	0,8	60	10	6	8 Nm
60	63	22	1,2	0,8	60	13	8	25 Nm
64	67	22	1,2	0,8	60	13	8	25 Nm
68	73	24	1,5	0,8	65	13	8	25 Nm
74	79	24	1,5	0,8	65	13	8	25 Nm
80	85	24	1,5	0,8	75	13	8	25 Nm
86	91	24	1,5	0,8	75	13	8	25 Nm
92	97	24	1,5	0,8	75	13	8	25 Nm
98	103	24	1,5	0,8	75	13	8	25 Nm
104	112	24	1,5	0,8	80	13	8	25 Nm
110	118	24	1,5	0,8	80	13	8	25Nm
113	121	24	1,5	0,8	80	13	8	25 Nm
122	130	24	1,5	0,8	80	13	8	25 Nm
131	139	26	1,7	1	105	17	10	50 Nm
140	148	26	1,7	1	105	17	10	50 Nm
149	161	26	1,7	1	105	17	10	50 Nm
162	174	26	1,7	1	105	17	10	50 Nm
175	187	26	1,7	1	120	17	10	50 Nm
188	200	26	1,7	1	120	17	10	50 Nm
201	213	26	1,7	1	120	17	10	50 Nm
214	226	26	1,7	1	120	17	10	50 Nm
227	239	26	1,7	1	120	17	10	50 Nm
240	252	26	1,7	1	120	17	10	50 Nm

AD\*= Maximum advised torque. We recommend working on 72% of the maximum values.



Material:  
W1, W2, W4, W5

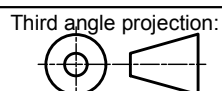

Part number:  
**S clamp**

Description:  
MPC Industries Super clamp

Revision:

**A**

Drawn by: Gy.Kardos

Creation date: 17-10-2016

Scale 1:1

Units: mm

Format:

**A4**

Revision history

Rev.	Date	Description	ENGINEER
A	19-9-2017	Added the missing S110 which is in SAP	M. Wiersma

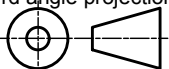
	Material:	Part number:	
	Third angle projection: 	Description:	Revision: <b>A</b>
Drawn by: Gy.Kardos	Creation date: 17-10-2016	Format: <b>A4</b>	
Scale 1:1	Units: mm		
MPC Industries B. V. Badweg 38 8401 BL Gorredijk Postbus 225 8400 AE Gorredijk. Tel.: . 0513 465477 Fax.: 0513 465736			